



WHEEL GUIDE



Catalog 2026-27



Made To Order, In The U.S.A. By Real Car Guys

SMOOTHIE WHEELS

AVAILABLE IN 14", 15", 16", 17", 18" and 20" Sizes

Bolt Patterns: [5 on 4.5"], [5 on 4.75"], [5 on 5"], [5 on 5.5"], [6 on 5.5"]



BARE SMOOTHIE
06 SERIES



CHROME RIM/BARE CENTER
07 SERIES



CHROME SMOOTHIE
60 SERIES

WHEEL SIZE	STANDARD MINIMUM	STANDARD MAXIMUM	REVERSE MINIMUM	REVERSE MAXIMUM
14x5	2.50	3.625	1.75	2.75
14x5.5	3.00	3.75	2.00	2.75
14x6	3.25	4.50	2.00	3.00
15x4.5	1.75	3.00	N/A	N/A
15x5	2.50	3.25	1.75	2.75
15x6	3.25	3.875	2.25	2.75
15x7	3.75	5.00	2.00	3.25
15x8	4.00	6.00	2.00	4.25
15x10	4.00	7.50	2.75	6.00
15x12	4.25	9.50	3.50	7.75
15x14	4.25	11.25	2.50	10.00
16x4.5	2.25	3.00	N/A	N/A
16x6	3.75	4.50	2.00	2.75
16x7	4.00	5.50	2.25	3.50
16x8	4.00	6.25	2.25	3.50
16x10	3.75	8.25	2.25	6.50
16x12	4.75	9.50	2.75	7.50
17x5.5	2.00	4.00	N/A	N/A
17x7	3.00	5.875	2.125	5.00
17x8	3.125	6.875	2.25	5.75
17x9	3.25	7.75	2.25	5.75
17x10	5.25	8.75	2.25	5.75
17x12	Call for exact backspace			
18x5.5	2.75	3.75	1.50	2.375
18x7	4.375	5.25	1.50	2.50
18x8	3.50	6.25	1.75	4.125
18x9	5.625	7.25	1.625	5.25
18x10	4.50	8.75	2.25	5.75
18x12	Call for exact backspace			
20x8	4.25	6.50	2.25	4.50
20x9	5.00	7.50	2.50	5.25
20x11	4.75	9.50	2.50	7.50

More 20" Wheel Sizes Coming Soon.



SMOOTHIE ACCESSORIES



Baby Moon



Plain Interceptor
Available w/Bowtie



Hollywood Flipper



Hollywood Plain



'40 Ford Deluxe



'41 Ford



'42 Ford



'46 Ford



'47 Ford



'41-'47 Chevrolet



'47-'53 Chevy Pickup



'47-53 GMC



'49 Chevy



'54-'55 Chevy Pickup



'55-'56 Chevy Pickup



'55-'59 GMC



Shannon Cone



Smooth Trim Ring



Ribbed Trim Ring



'32 Ford V8*



'32-'33 Ford 4 cylinder*



'32-'35 Ford Plain*



'33 Ford V8*



'34 Ford 4 Cylinder*



'34 Ford Plain*



'34 Ford V8*



'35 Ford V8*

*Caps must use Adapter Ring



Adapter Ring



CALL OUR ORDER HOT-LINE

800-854-8937 • 951-898-4563

TheWheelsmith.net



VINTAGE WHEELS

AVAILABLE IN 15" and 16"

Bolt Patterns: [5 on 4.5", 5 on 4.75"], [5 on 5.5"]



BARE VINTAGE
04 SERIES

WHEEL SIZE	STANDARD MINIMUM	STANDARD MAXIMUM	REVERSE MINIMUM	REVERSE MAXIMUM
15x4.5	1.50	2.625	N/A	N/A
15x5	2.25	3.00	1.50	2.25
15x6	3.00	3.50	2.00	2.25
15x7	3.50	5.00	2.00	3.00
15x8	3.75	5.75	1.75	4.00
15x10	3.75	7.25	2.25	5.75
15x12	4.25	10.00	2.25	7.25
15x14	4.50	12.00	2.25	9.00
16x4.5	2.25	2.75	N/A	N/A
16x6	3.50	4.25	2.25	3.00
16x7	4.25	5.50	2.25	3.50
16x8	4.00	6.25	2.25	4.25
16x10	4.00	7.00	2.25	5.25
16x12	4.00	9.75	2.25	7.25



CHROME RIM/BARE CENTER
05 SERIES

WHEEL SIZE	STANDARD MINIMUM	STANDARD MAXIMUM	REVERSE MINIMUM	REVERSE MAXIMUM
15x4.5	1.50	2.625	N/A	N/A
15x5	2.25	3.00	1.50	2.25
15x6	3.00	3.50	2.00	2.25
15x7	3.50	5.00	2.00	3.00
15x8	3.75	5.75	1.75	4.00
15x10	3.75	7.25	2.25	5.75
15x12	4.25	10.00	2.25	7.25
15x14	4.50	12.00	2.25	9.00
16x4.5	2.25	2.75	N/A	N/A
16x6	3.50	4.25	2.25	3.00
16x7	4.25	5.50	2.25	3.50
16x8	4.00	6.25	2.25	4.25
16x10	4.00	7.00	2.25	5.25
16x12	4.00	9.75	2.25	7.25



CHROME VINTAGE
40 SERIES

WHEEL SIZE	STANDARD MINIMUM	STANDARD MAXIMUM	REVERSE MINIMUM	REVERSE MAXIMUM
15x4.5	1.50	2.625	N/A	N/A
15x5	2.25	2.75	1.50	2.25
15x6	3.00	3.50	2.00	2.25
15x7	3.50	5.00	2.00	3.00
15x8	3.75	5.75	1.75	4.00
15x10	3.75	7.25	2.25	5.75
15x12	4.25	10.00	2.25	7.25
15x14	4.50	12.00	2.25	9.00
16x4.5	2.25	2.75	N/A	N/A
16x6	3.50	4.25	2.25	3.00
16x7	4.25	5.50	2.25	3.50
16x8	4.00	6.25	2.25	4.25
16x10	4.00	7.00	2.25	5.25
16x12	4.00	9.75	2.25	7.25

VINTAGE ACCESSORIES



Hollywood Flipper



Hollywood Plain



'40 Ford V8



'40 Ford Deluxe



'41 Ford



'42 Ford



'46 Ford



'47 Ford



'41-'47 Chevrolet



'47-'53 Chevy Pickup



'47-'53 GMC



'49 Chevy



'54-'55 Chevy Pickup



'55-'56 Chevy Pickup



'55-'59 GMC



Smooth Trim Ring

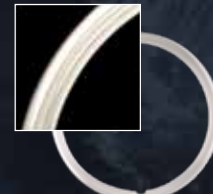

Ribbed Trim Ring



'32 Ford V8*



'32-'33 Ford 4 cylinder*



'32-'35 Ford Plain*



'33 Ford V8*



'34 Ford 4 Cylinder*



'34 Ford Plain*



'34 Ford V8*



'35 Ford V8*

*Caps must use Adapter Ring



CALL OUR ORDER HOT-LINE

800-854-8937 • 951-898-4563

TheWheelsmith.net



ARTILLERY WHEELS

AVAILABLE IN 15"

Bolt Patterns: [5 on 4.5", 5 on 4.75"], [5 on 5.5"]



BARE ARTILLERY
01 SERIES

WHEEL SIZE	STANDARD MINIMUM	STANDARD MAXIMUM	REVERSE MINIMUM	REVERSE MAXIMUM
15x4.5	1.75	2.50	N/A	N/A
15x5	2.50	3.00	1.75	2.25
15x6	3.25	3.75	2.00	2.50
15x7	3.75	5.00	2.00	3.00
15x8	3.75	5.75	2.00	4.00
15x10	4.00	7.25	2.50	6.00
15x12	4.25	8.75	2.25	7.50
15x14	3.25	9.50	2.25	9.25



CHROME RIM/BARE CENTER
11 SERIES

WHEEL SIZE	STANDARD MINIMUM	STANDARD MAXIMUM	REVERSE MINIMUM	REVERSE MAXIMUM
15x4.5	1.75	2.50	N/A	N/A
15x5	2.50	3.00	1.75	2.25
15x6	3.25	3.75	2.00	2.50
15x7	3.75	5.00	2.00	3.00
15x8	3.75	5.75	2.00	4.00
15x10	4.00	7.25	2.50	6.00
15x12	4.25	8.75	2.25	7.50
15x14	3.25	9.50	2.25	9.25



CHROME ARTILLERY
10 SERIES

WHEEL SIZE	STANDARD MINIMUM	STANDARD MAXIMUM	REVERSE MINIMUM	REVERSE MAXIMUM
15x4.5	1.75	2.50	N/A	N/A
15x5	2.50	3.00	1.75	2.25
15x6	3.25	3.75	2.00	2.50
15x7	3.75	5.00	2.00	3.00
15x8	3.75	5.75	2.00	4.00
15x10	4.00	7.25	2.50	6.00
15x12	4.25	8.75	2.25	7.50
15x14	3.25	9.50	2.25	9.25

ARTILLERY ACCESSORIES



'40 Ford V8



'40 Ford Deluxe



'41 Ford



'42 Ford



'46 Ford



'47 Ford



'41-'47 Chevrolet



'47-'53 Chevrolet Pickup



'47-'53 GMC



'49 Chevy



'54-'55 Chevy Pickup



'55-'56 Chevy Pickup



'55-'59 GMC



Smooth Trim Ring



Ribbed Trim Ring



'32 Ford V8*



'32-'33 Ford 4 cylinder*



'32-'35 Ford Plain*



'33 Ford V8*



'34 Ford 4 Cylinder*



'34 Ford Plain*



'34 Ford V8*



'35 Ford V8*

*Caps must use Adapter Ring



CALL OUR ORDER HOT-LINE

800-854-8937 • 951-898-4563

TheWheelsmith.net



OEM STYLE WHEELS

AVAILABLE IN 15", 17" and 18" Need 20"? Call for Availability
 Bolt Patterns: [5 on 4.5"], [5 on 4.75"], [5 on 5"], [5 on 5.5"], [6 on 5.5"]



BARE OEM
02 SERIES



CHROME RIM/BARE CENTER
12 SERIES



CHROME OEM
20 SERIES

WHEEL SIZE	STANDARD MINIMUM	STANDARD MAXIMUM	REVERSE MINIMUM	REVERSE MAXIMUM
15x4.5	1.75	3.00	N/A	N/A
15x5	2.50	3.25	1.75	2.75
15x6	3.25	3.875	2.25	2.75
15x7	3.75	5.00	2.00	3.25
15x8	4.00	6.00	2.00	4.25
15x10	4.00	7.50	2.75	6.00
15x12	4.25	9.50	3.50	7.75
15x14	4.25	11.25	2.50	10.00
17x5.5	2.00	4.00	N/A	N/A
17x7	3.00	5.875	2.125	5.00
17x8	3.125	6.875	2.25	5.75
17x9	3.25	7.75	2.25	5.75
17x10	5.25	8.75	2.25	5.75
17x12	Call for exact backspace			
18x5.5	2.75	3.75	1.50	2.375
18x7	4.375	5.25	1.50	2.50
18x8	3.50	6.25	1.75	4.125
18x9	5.625	7.25	1.625	5.25
18x10	4.50	8.75	2.25	5.75
18x12	Call for exact backspace			



OEM STYLE 8-LUG WHEELS

AVAILABLE IN 16" Bolt Pattern: [8 on 6.5"]



BARE OEM 8-LUG
02 SERIES

WHEEL SIZE	STANDARD MINIMUM	STANDARD MAXIMUM	REVERSE MINIMUM	REVERSE MAXIMUM
16x4.5	2.25	3.00	N/A	N/A
16x6	3.75	4.50	2.00	2.75
16x7	4.00	5.50	2.25	3.50
16x8	4.00	5.50	2.25	3.50
16x10	3.75	8.25	2.25	6.50
16x12	4.75	9.50	2.75	7.50

OEM STYLE WHEEL ACCESSORIES



'49-'50 Ford



'49-'50 Ford
Plain



'50 Mercury



'51 Ford



'55-'56 Ford



'64-'66
Chevy

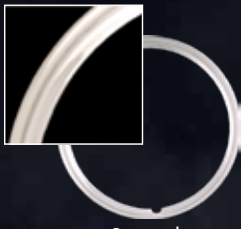

Smooth
Trim Ring

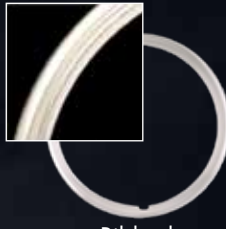

Ribbed
Trim Ring



Spider
Trim Ring



Spider Cap



CALL OUR ORDER HOT-LINE

800-854-8937 • 951-898-4563

TheWheelsmith.net

RALLYE WHEELS

AVAILABLE IN 14", 15" & 16".

Bolt Patterns: [5 on 4.5", 5 on 4.75"], [5 on 5", 5 on 5.5"], [6 on 5.5"]



BARE RALLYE
08 SERIES

WHEEL SIZE	STANDARD MINIMUM	STANDARD MAXIMUM	REVERSE MINIMUM	REVERSE MAXIMUM
14x6	3.25	4.25	2.00	3.00
15x4.5	3.25	2.75	2.00	2.50
15x5	2.75	3.25	2.00	2.50
15x6	3.50	4.25	2.00	3.00
15x7	3.75	5.25	2.25	3.50
15x8	4.00	6.00	2.25	4.25
15x10	4.50	7.50	2.75	6.00
15x12	4.50	10.00	2.75	7.75
15x14	4.25	12.00	2.75	9.50



CHROME RIM/BARE CENTER
09 SERIES

WHEEL SIZE	STANDARD MINIMUM	STANDARD MAXIMUM	REVERSE MINIMUM	REVERSE MAXIMUM
14x6	3.25	4.25	2.00	3.00
15x4.5	3.25	2.75	2.00	2.50
15x5	2.75	3.25	2.00	2.50
15x6	3.50	4.25	2.00	3.00
15x7	3.75	5.25	2.25	3.50
15x8	4.00	6.00	2.25	4.25
15x10	4.50	7.50	2.75	6.00
15x12	4.50	10.00	2.75	7.75
15x14	4.25	12.00	2.75	9.50



CHROME RALLYE
80 SERIES

WHEEL SIZE	STANDARD MINIMUM	STANDARD MAXIMUM	REVERSE MINIMUM	REVERSE MAXIMUM
14x6	3.25	4.25	2.00	3.00
15x4.5	3.25	2.75	2.00	2.50
15x5	2.75	3.25	2.00	2.50
15x6	3.50	4.25	2.00	3.00
15x7	3.75	5.25	2.25	3.50
15x8	4.00	6.00	2.25	4.25
15x10	4.50	7.50	2.75	6.00
15x12	4.50	10.00	2.75	7.75
15x14	4.25	12.00	2.75	9.50

RALLYE WHEEL ACCESSORIES



Baby Moon



Plain
Interceptor
Available w/Bowtie



'40 Ford V8



'40 Ford
Deluxe



'41 Ford



'42 Ford



'46 Ford



'47 Ford



'41-'47
Chevrolet



'47-'53
Chevy Pickup



'47-'53
GMC



'49 Chevy



'54-'55
Chevy Pickup



'55-'56
Chevy Pickup



'55-'59
GMC



Shannon
Cone



Disk Brake
Rallye Cap



Sombrero
Cap



Smooth
Trim Ring

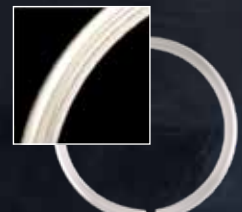

Ribbed
Trim Ring



CALL OUR ORDER HOT-LINE

800-854-8937 • 951-898-4563

TheWheelsmith.net

HOT ROD WIRE WHEELS

AVAILABLE IN 14", 15", 16", 17", 18" and 20"

Bolt Patterns: [5 on 4.5", 5 on 4.75"], [5 on 5", 5 on 5.5"]

Also available with Stainless Steel Spokes and Nipples at Additional Cost.



BARE HOT ROD WIRE
03 SERIES

WHEEL SIZE

14x5.5
14x6
15x4.5
15x5
15x6
15x7
15x7
15x8
15x8
15x8
15x10

AVAILABLE BACKSPACE

2.50
3.00
1.50
2.00
3.00
3.50
4.00
3.50
4.25
5.00
4.25

WHEEL SIZE

16x4.5
16x6
16x7
16x7
16x8
16x10
17x5.5
17x7
17x8
17x9
18x5.5
18x8
20x5.5
20x8

AVAILABLE BACKSPACE

1.50
3.00
3.50
3.50-4.00
3.50-5.00
4.50
2.50
4.00
4.00
4.00
2.50
4.00
2.25
4.25

18" and 20" More Sizes Available



POWDERCOAT/CHROME SPOKE
13 SERIES

WHEEL SIZE

14x5.5
14x6
15x4.5
15x5
15x6
15x7
15x7
15x8
15x8
15x8
15x10

AVAILABLE BACKSPACE

2.50
3.00
1.50
2.00
3.00
3.50
4.00
3.50
4.25
5.00
4.25

WHEEL SIZE

16x4.5
16x6
16x7
16x7
16x8
16x10
17x5.5
17x7
17x8
17x9
18x5.5
18x8
20x5.5
20x8

AVAILABLE BACKSPACE

1.50
3.00
3.50
3.50-4.00
3.50-5.00
4.50
2.50
4.00
4.00
4.00
2.50
4.00
2.25
4.25

18" and 20" More Sizes Available

HOT ROD WIRE WHEELS

AVAILABLE IN 14", 15", 16", 17", 18" and 20"

Bolt Patterns: [5 on 4.5", 5 on 4.75"], [5 on 5", 5 on 5.5"]

Also available with Stainless Steel Spokes and Nipples at Additional Cost.



WHEEL SIZE

14x5.5
14x6
15x4.5
15x5
15x6
15x7
15x7
15x8
15x8
15x8
15x10

AVAILABLE BACKSPACE

2.50
3.00
1.50
2.00
3.00
3.50
4.00
3.50
4.25
5.00
4.25

WHEEL SIZE

16x4.5
16x6
16x7
16x7
16x8
16x10
17x5.5
17x7
17x8
17x9
18x5.5
18x8
20x5.5
20x8

AVAILABLE BACKSPACE

1.50
3.00
3.50
3.50-4.00
3.50-5.00
4.50
2.50
4.00
4.00
4.00
2.50
4.00
2.25
4.25

18" and 20" More Sizes Available

ALL CHROME HOT ROD WIRE
30 SERIES

HOT ROD WIRE WHEEL ACCESSORIES



Smooth
Trim Ring



Ribbed
Trim Ring



'32 Ford V8



'32-'33 Ford
4 cylinder



'32-'35 Ford
Plain



'33 Ford V8



'34 Ford
4 Cylinder



'34 Ford
Plain



'34 Ford V8



'35 Ford V8



CALL OUR ORDER HOT-LINE

800-854-8937 • 951-898-4563

TheWheelsmith.net

SPECIALTY WIRE WHEELS

56 SPOKE ALL CHROME, ADD FOR STAINLESS STEEL
 BOLT PATTERNS: [5 on 4.5" / 4.75"], [5 on 5" / 4.75"], 5 on 5.5"



CHRYSLER/DODGE/PLYMOUTH/IMPERIAL

WHEEL SIZE	AVAILABLE BACKSPACE	VEHICLE FITMENT
14X6	3.00	Chrysler/Dodge/Plymouth
15X6	3.00	Chrysler/Dodge/Plymouth
15X6	3.00	Imperial

14" - 18" AVAILABLE

58 SERIES CHROME
 59 SERIES STAINLESS

56 SPOKE ALL CHROME, ADD FOR STAINLESS STEEL
 BOLT PATTERNS: [5 on 4.5" / 4.75"], [5 on 5" / 4.75"], 5 on 5.5"



PACKARD WIRE WHEELS

WHEEL SIZE	AVAILABLE BACKSPACE
15X6	3.00

14" - 18" AVAILABLE



46 SERIES CHROME
 47 SERIES STAINLESS

56 SPOKE ALL CHROME, ADD FOR STAINLESS STEEL
 BOLT PATTERNS: [5 on 4.5" / 4.75"], [5 on 5" / 4.75"], 5 on 5.5"



CADILLAC WIRE WHEELS

WHEEL SIZE	AVAILABLE BACKSPACE	VEHICLE FITMENT
15X6	3.50	1941-1956
15X6	3.00	1957 AND UP

14" - 18" AVAILABLE

42 SERIES CHROME
 43 SERIES STAINLESS

CLASSIC WIRE WHEELS

56 SPOKE ALL CHROME, ADD FOR STAINLESS STEEL
 BOLT PATTERNS: [5 on 4.5" / 4.75"], [5 on 5" / 4.75"], 5 on 5.5"



44 SERIES CHROME

WHEEL
 SIZE

14X6
 15X6
 15X7

AVAILABLE
 BACKSPACE

3.00
 3.00
 4.00



FORD
 CREST
 CAPS
 AVAILABLE



45 SERIES STAINLESS

56 SPOKE ALL CHROME, ADD FOR STAINLESS STEEL
 BOLT PATTERNS: [5 on 4.5" / 4.75"], [5 on 5" / 4.75"]



56 SERIES CHROME
 57 SERIES STAINLESS

THUNDERBIRD WIRE WHEELS

WHEEL
 SIZE

14X5
 14X5.5
 15X5
 15X6
 15X6

AVAILABLE
 BACKSPACE

3.25
 3.75
 3.50
 3.50
 4.00

VEHICLE
 FITMENT

1957 Only
 1958-1964
 1955-1956
 1965-1967 Front
 1965-1967 Rear



AVAILABLE CAPS



CALL OUR ORDER HOT-LINE

800-854-8937 • 951-898-4563

TheWheelsmith.net

ALUMINUM WHEELS

BILLET ALUMINUM ARTILLERY



BILLET MOPAR ARTILLERY
110 SERIES

WHEEL SIZE

16x7
16x8
16x9.5
17x7
17x8
17x9
17x9.5
17x11
18x7
18x8
18x9.5
20x8
20x9.5



BILLET ARTILLERY
101 SERIES

WHEEL SIZE

16x7
16x8
16x9.5
17x7
17x8
17x9
17x9.5
17x11
18x7
18x8
18x9.5
20x8
20x9.5

CAST ALUMINUM ARTILLERY



CAST ALUMINUM ARTILLERY
201 SERIES

WHEEL SIZE

17x7
17x8
17x10
18x7
18x8
18x10



CAST ALUMINUM ARTILLERY
201 SERIES

WHEEL SIZE

17x7
17x8
17x10
18x7
18x8
18x10



ALUMINUM WHEELS



BILLET RALLYE
108 SERIES

WHEEL SIZE

- 16x7
- 16x8
- 16x9.5
- 17x7
- 17x8
- 17x9
- 17x9.5
- 17x11
- 18x7
- 18x8
- 18x9.5
- 20x8
- 20x9.5



BILLET OEM
102 SERIES

WHEEL SIZE

- 16x7
- 16x8
- 16x9.5
- 17x7
- 17x8
- 17x9
- 17x9.5
- 17x11
- 18x7
- 18x8
- 18x9.5
- 20x8
- 20x9.5



CAST ALUMINUM DIRT TRACK
212 SERIES

WHEEL SIZE

- 15x4
- 15x5
- 15x6
- 15x7
- 15x8
- 15x10
- 15x10
- 15x12
- 17x7
- 17x8
- 17x10



BILLET SMOOTHIE
106 SERIES

WHEEL SIZE

- 16x7
- 16x8
- 16x9.5
- 17x7
- 17x8
- 17x9
- 17x9.5
- 17x11
- 18x7
- 18x8
- 18x9.5
- 20x8
- 20x9.5



CALL OUR ORDER HOT-LINE

800-854-8937 • 951-898-4563

TheWheelsmith.net



HOW TO MEASURE YOUR CAR FOR PROPER WHEEL FITMENT.

Jack vehicle up on level ground by the suspension. Remove the lug nuts and wheels. Support the car with Jack Stands at the suspension. Be sure the hub's mounting surface is vertical. Use a rigid straight edge for all measurements, about 30" long for best results. When measuring from the mounting surface, be sure to use that side of the straight edge for measurements.

STEP BY STEP

- Measure the mounting surface to the fender edge at the highest point (B).
- Measure from the mounting surface to the first obstruction on the frame side at that verticle point of the fender edge (A).
- Measure the hub diameter (C).
- Measure radius from the hub center to top of the brake caliper (D).
- Measure the mounting surface to the outer edge of brake caliper (E).
- Measure the hub length from the mounting surface (F).
- Measure the distance from the center of hub and top of fender lip (H).

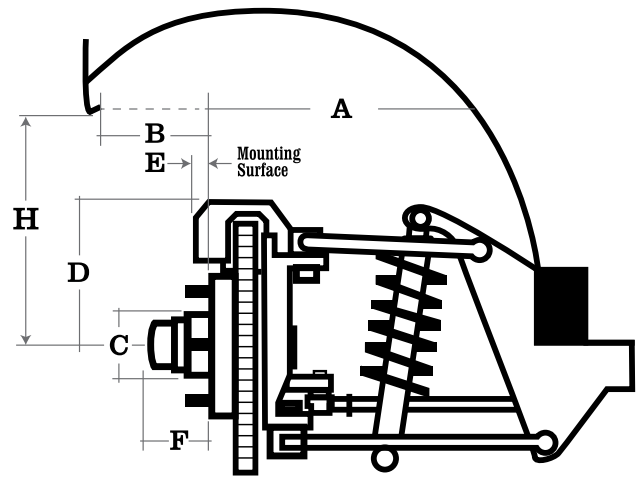

FRONT WHEEL

Left (drivers side)

Right (pass. side)

A: _____ B: _____

A: _____ B: _____

C: _____ D: _____

C: _____ D: _____

E: _____ F: _____

E: _____ F: _____

H: _____

H: _____

CURRENT WHEELS:

WHEEL STYLE _____	BOLT PATTERN _____
FRONT WHEEL SIZE _____	REAR WHEEL SIZE _____
FRONT BACKSPACE _____	REAR BACKSPACE _____
FRONT TIRE SIZE _____	REAR TIRE SIZE _____

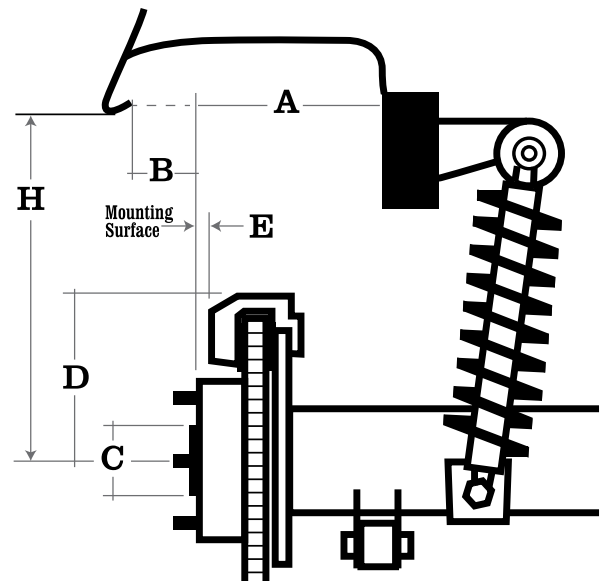
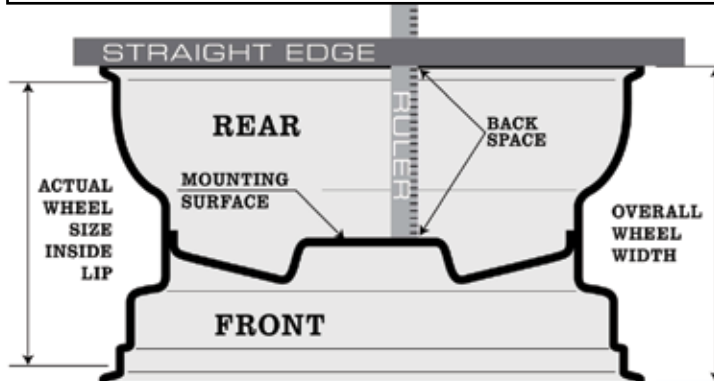

Left (drivers side)

Right (pass. side)

A: _____ B: _____

A: _____ B: _____

C: _____ D: _____

C: _____ D: _____

E: _____ H: _____

E: _____ H: _____

FAX THE COMPLETED WORKSHEET TO WHEELSMITH AT: 951-340-0562



The Wheelsmith Limited Warranty

The Wheelsmith chrome wheels and accessories are warranted for a period of 6 months from the date of purchase to the original owner. Oxidation or corrosion of the finish due to neglect and/or adverse weather or chemicals is not covered by this warranty. The Wheelsmith assumes no responsibility for diagnosis, removal and installation labor, loss of vehicle use, loss of time, inconvenience, painting or other consequential damages or expense.

Any claim made pursuant to this warranty regarding crooked wheels shall be conditioned upon the Wheelsmith's inspection thereof.

Those claiming under this warranty shall, at Wheelsmith's option, having the following remedy against Wheelsmith in substitution for all other remedies or rights: The right to (a) repayment, or credit towards the purchase of a new wheel; or (b) the replacement of said wheel or accessory. There is no warranty on any painted or powder-coated products.

There are no returns allowed on custom offset wheels, or O.E.M. -type wheel applications. There are no returns allowed after thirty (30) days. No exceptions.

There will be a twenty percent (20%) restocking charge on all returned items and no allowance for freight charges incurred. All return items **MUST BE** accompanied by a return authorization number and a copy of your receipt. **YOU PAINT IT, YOU MOUNT IT... YOU OWN IT!**



CALL OUR ORDER HOT-LINE

800-854-8937 • 951-898-4563

TheWheelsmith.net

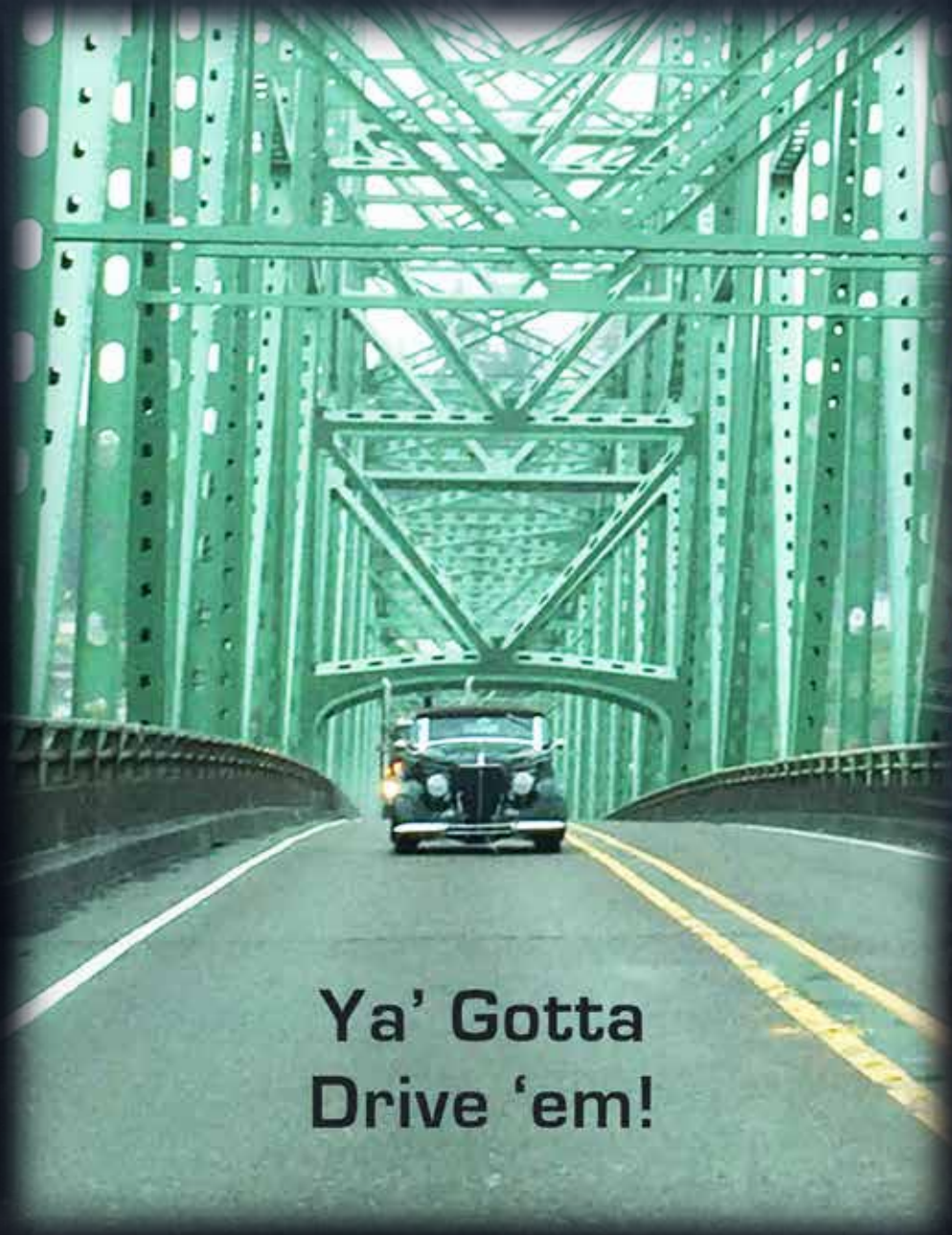

Ya' Gotta
Drive 'em!



CALL OUR ORDER HOT-LINE

800-854-8937 • 951-898-4563

TheWheelsmith.net

1601 Commerce St., Corona, CA 92878



©2026 Wheelsmith • \$5.00